



Water Tank Truck Bodies

***Extracted from Full Scelzi Catalog
January 2024***



Key Features and Options on Scelzi Water Trucks



Three square Manholes on 4000 gallon tanks

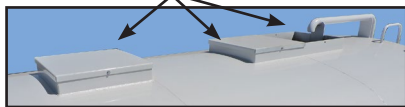

Cab control box

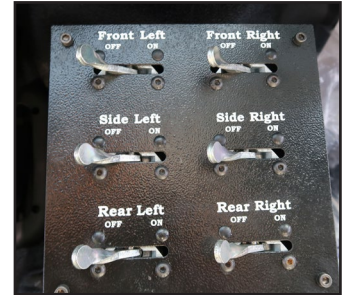

Two 24" x 24" Manholes

3/16" thick steel tank skins welded inside and out

2.5" Hydrant Fill Pipe

Optional Hose Reel

Driver and passenger-side Adjustable Spray Fittings

Front and Rear Spray Bars

Heavy Duty Steel Ladder



24" Stinger Storage with lockable lid

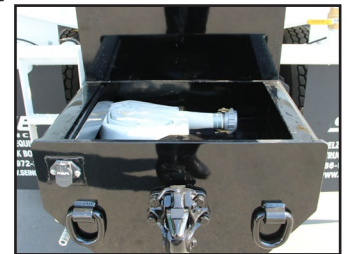

Unique Scelzi Water Tank Features:

- A-Rubber Mounts between the long sill and chassis to minimize vibration
- B-Spring tank mounts to act as shock absorbers independent of the chassis



Optional LED Enhanced Light Kit



Optional 1/4" Thick Belly Steel Overlay



Photos may contain optional equipment - verify your specifications when you order.

WT-2000

2,000 Gallons

Standard Specifications

Standard

- Features:**
- Chelsea Air Shift PTO
 - 4" x 3" Berkeley water pump (750 GPM)
 - Spicer PTO Driveline
 - 4" x 4" Water Manifold
 - 3" Standard Air Valves
 - 3" Slip on splash spray heads for front
 - 3" x 53" Front spray bar with mounting brackets
 - 3" Slip on splash spray heads for rear
 - 3" x 53" Rear spray bar with mounting brackets
 - 3" Adjustable driver side spray with VIC clamps
 - 3" Adjustable passenger side spray with VIC clamps
 - One control box inside cab with (6) air switches and Air control for PTO
 - 1-1/2" Gate valve at manifold
 - 3/4" Gate valve at manifold
 - 4" Water tank mounts with 3/4" bolts
 - One set of water tank fenders with hooks for hoses
 - OEM Tail Stop & turn rear lights
 - 2-1/2" Red marker lights seal beam
 - 2-1/2" Amber marker lights seal beam
 - 36" Rubber mud flaps
 - 24" Stinger at rear with lockable lid
 - 1/2" Sight gauge at rear

Options:

- Hot shift PTO for Allison Transmission
- Upgrade to CLA – Val Air Valves
- 1/4" Thick overlay "Belly" at lower level of standard 3/16" thick tank, which significantly slows "rot-out" of bottom of tank
- 6" Diameter gravity water tank dump valve at rear bottom of tank with "Fan Nozzle".

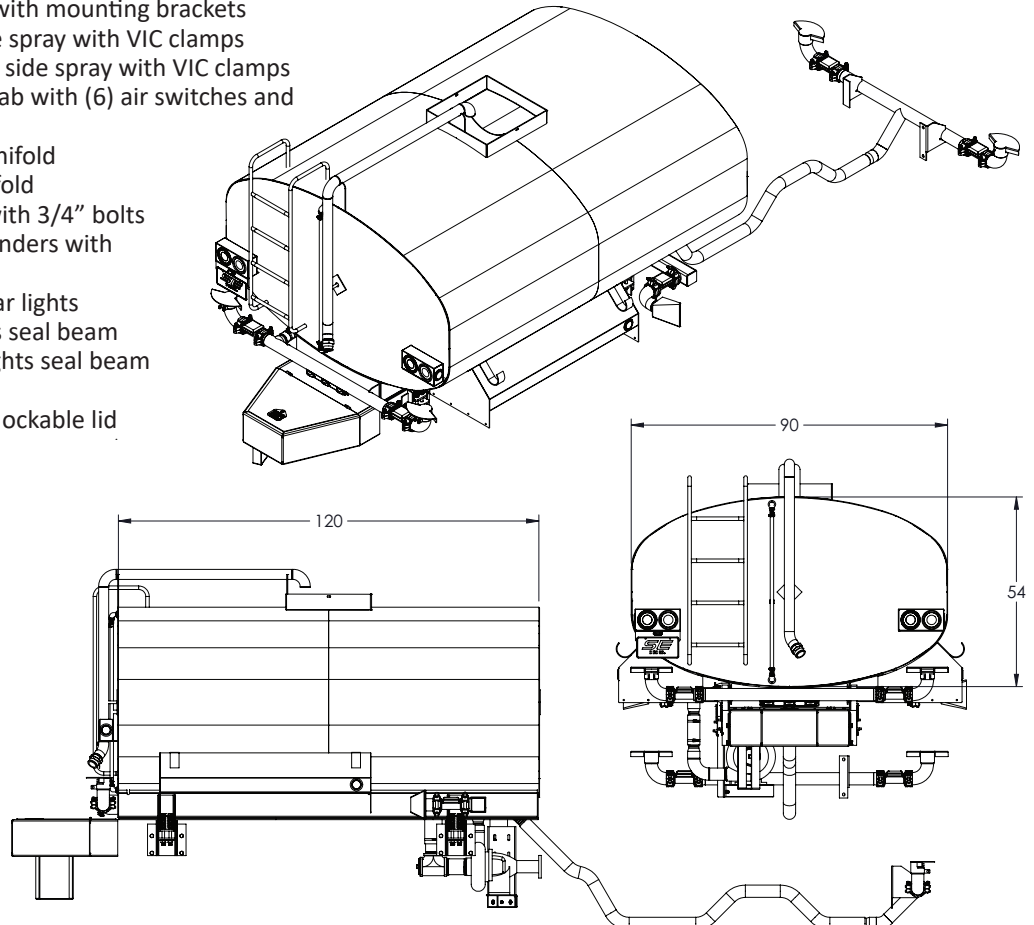



Photos may contain optional equipment - verify your specifications when you order.

WT-2500

2,500 Gallons

Standard Specifications

Standard Features:

- Chelsea Air Shift or Hot Shift PTO
- 4" x 3" Berkeley water pump (750 GPM)
- Spicer PTO Driveline
- 4" x 4" Water Manifold
- One set of water tank fenders with hooks for hoses
- 4" Water tank mounts with 3/4" bolts
- OEM tail stop & turn rear lights
- 3" Standard Air Valves
- 3" Slip on splash spray heads for front
- 3" x 53" Front spray bar with mounting brackets
- 3" Slip on splash spray heads for rear
- 3" x 53" Rear spray bar with mounting brackets
- 3" Adjustable driver side spray with VIC clamps
- 3" Adjustable passenger side spray with VIC clamps
- One control box inside cab with (6) air switches and Air control for PTO
- 1-1/2" Gate valve at manifold
- 3/4" Gate valve at manifold
- 2-1/2" Red marker lights seal beam
- 2-1/2" Amber market lights seal beam
- 36" Rubber mud flaps
- 24" Stinger at rear with lockable lid
- 1/2" Sight gauge at rear

Options:

- Hot shift PTO for Allison Transmission
- Upgrade to CLA – Val Air Valves
- 1/4" Thick overlay "Belly" at lower level of standard 3/16" thick tank which significantly slows "rot-out" of bottom of tank
- 6" Diameter gravity water tank dump valve at rear bottom of tank with "Fan Nozzle".

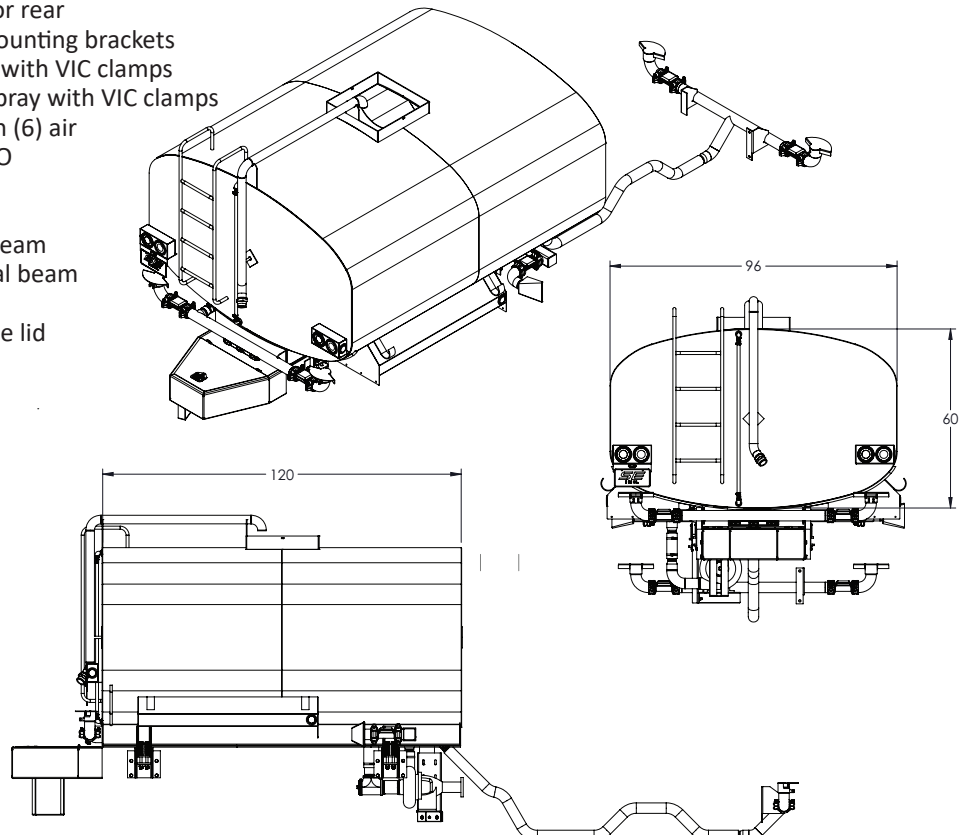



Photos may contain optional equipment - verify your specifications when you order.

WT-4000

4,000 Gallons

Standard Specifications

Standard

- Features:**
- Chelsea Air Shift PTO for manual transmission
 - 4" x 3" Berkeley water pump, (750 GPM)
 - Spicer PTO Driveline
 - 4" x 4" Water Manifold
 - 3" Standard Air Valves
 - 3" Slip on splash spray heads for front
 - 3" x 53" Front spray bar with mounting brackets
 - 3" Slip on splash spray heads for rear
 - 3" x 53" Rear spray bar with mounting brackets
 - 3" Adjustable S/S spray with VIC clamps
 - 3" Adjustable C/S spray with VIC clamps
 - One control box inside cab with (6) air switches and Air control for PTO
 - OEM tail stop and turn rear lights
 - 2-1/2" Red marker lights seal beam
 - 2-1/2" Amber marker lights seal beam
 - 36" Rubber mud flaps
 - 24" Stinger at rear with lockable lid
 - 1/2" Sight gauge at rear
 - 1-1/2" Gate valve at manifold
 - 3/4" Gate valve at manifold
 - 4" Water tank mounts with 3/4" bolts
 - One set of water tank fenders with hooks for hoses

Options:

- Hot shift PTO for Allison Transmission
- Upgrade to CLA – Val Air Valves
- 1/4" Thick overlay "Belly" at lower level of standard 3/16" thick tank, which significantly slows "rot-out" of bottom of tank
- 6" Diameter gravity water tank dump valve at rear bottom of tank with "Fan Nozzle".

